

SCALE 2 : 1

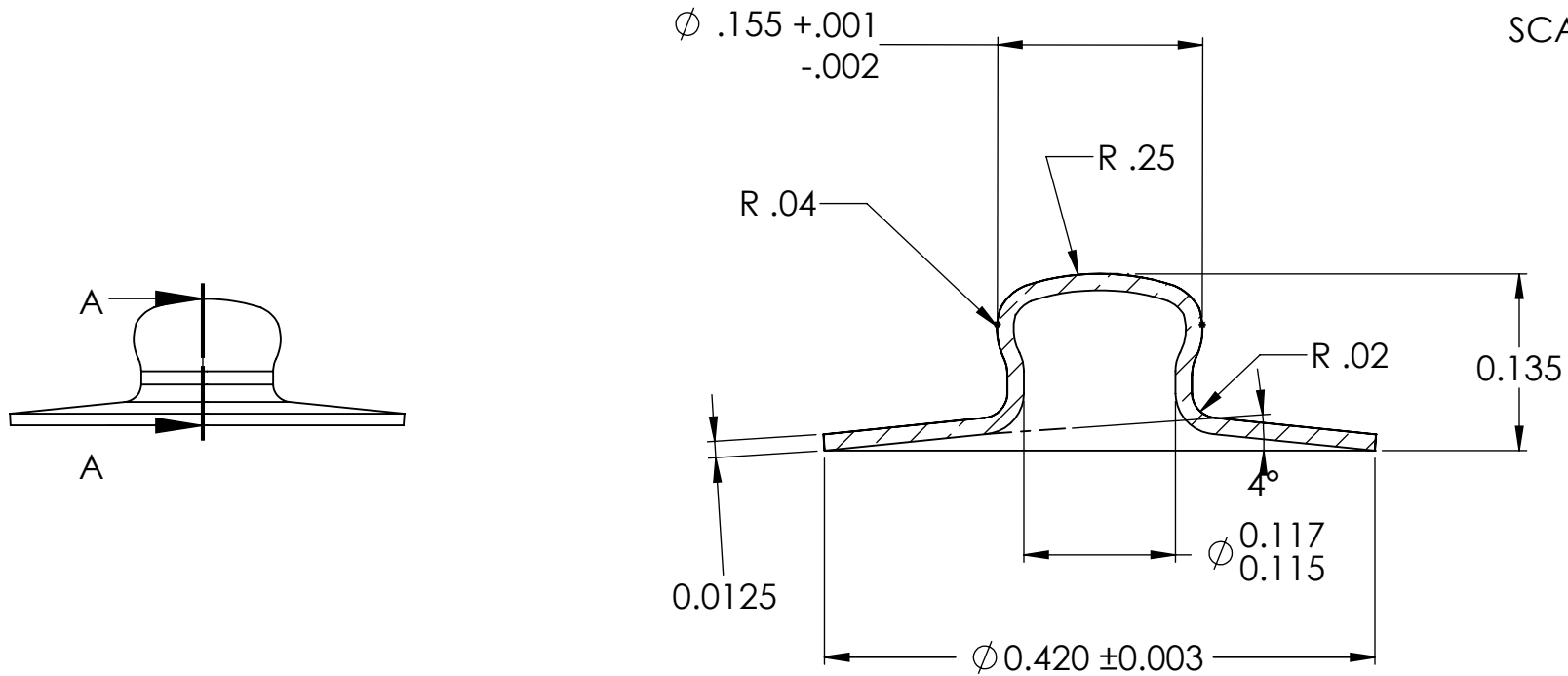

NOTES:

MATERIAL : 70/30 BRASS

ALL DIAMTERS MUST BE CONCENTRIC TO WITHIN .003 TIR

SECTION A-A
SCALE 7 : 1



PROPRIETARY AND CONFIDENTIAL
THE INFORMATION CONTAINED IN THIS DRAWING IS THE SOLE PROPERTY OF <INSERT COMPANY NAME HERE>. ANY REPRODUCTION IN PART OR AS A WHOLE WITHOUT THE WRITTEN PERMISSION OF <INSERT COMPANY NAME HERE> IS PROHIBITED.

		UNLESS OTHERWISE SPECIFIED:		NAME	DATE	TITLE: STUD							
		DIMENSIONS ARE IN INCHES TOLERANCES: FRACTIONAL ± ANGULAR: MACH ± BEND ± TWO PLACE DECIMAL ± THREE PLACE DECIMAL ±	DRAWN	crl	9.21.15			SIZE DWG. NO. REV A 14 STUD-R					
		INTERPRET GEOMETRIC TOLERANCING PER:	CHECKED							SCALE: 5:1 WEIGHT: SHEET 1 OF 1			
		MATERIAL	ENG APPR.									APPLICATION DO NOT SCALE DRAWING	
NEXT ASSY	USED ON	FINISH	MFG APPR.										
APPLICATION		DO NOT SCALE DRAWING	COMMENTS:										

5

4

3

2

1